

- EN** Installation / User Instructions / Warranty
- FR** Instructions de montage / Mode d'emploi / Garantie
- ES** Instrucciones de montaje / Manejo / Garantía

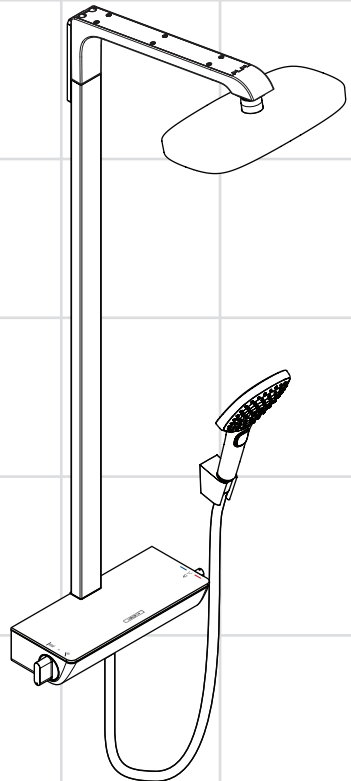

Raindance Select Showerpipe
04610400

Technical Information

Recommended water pressure	15 - 75 PSI
Max. water pressure	145 PSI
Recommended hot water temp.	120° - 140° F*
Max. hot water temp	176° F*
Flow rate - showerhead	2.0 GPM
Flow rate - handshower	2.0 GPM

* Please know and follow all applicable local plumbing codes when setting the temperature on the water heater.

Installation Considerations

- For best results, Hansgrohe recommends that this unit be installed by a licensed, professional plumber.
- Please read over these instructions thoroughly before beginning installation. Make sure that you have all tools and supplies needed to complete the installation.
- **This showerpipe must be used with with showerpipe rough set 16181181 (not included).**
- To guarantee the smooth running of the thermostat, it is necessary from time to time to turn the thermostat from total hot to total cold.
- The mixer is equipped with check valves. The check valves must be checked regularly (at least once a year) to insure reliable service of the mixer and to protect the drinking water supply from backflow. If the check valves are dirty or worn, they must be replaced.
- To prevent scald injury, the maximum output temperature of the shower valve must be no higher than 120°F. In Massachusetts, the maximum output temperature can be no higher than 112° F.
- Keep this booklet and the receipt (or other proof of date and place of purchase) for this product in a safe place. The receipt is required should it be necessary to request warranty parts.

Données techniques

Pression d'eau recommandée	15 - 75 PSI
Pression d'eau maximum	145 PSI
Température recommandée d'eau chaude	120° - 140° F*
Température maximum d'eau chaude	176° F*
Capacité nominale - pomme de douche	2.0 GPM
Capacité nominale - douchette	2.0 GPM

* Vous devez connaître et respecter tous les codes de plomberie locaux applicables pour le réglage de la température du chauffe-eau.

À prendre en considération pour l'installation

- Pour de meilleurs résultats, Hansgrohe recommande que ce produit soit installé par un plombier professionnel licencié.
- Veuillez lire attentivement ces instructions avant de procéder à l'installation. Assurez-vous de disposer de tous les outils et du matériel nécessaires pour l'installation.
- **Cet appareil doit être installé avec l'ensemble de base 16181181 (non fourni).**
- Pour assurer le mouvement facile de l'élément thermostatique, le thermostat devrait être placé de temps en temps en position très chaude et très froide.
- Le mitigeur thermostatique est équipé de clapets anti-retour. Les clapets anti-retour doivent être examinés régulièrement conformément aux dispositions nationales ou régionales quant à leur fonction (au moins une fois par an).
- Pour empêcher des blessures par ébullition, la température de sortie maximale du robinet de douche ne doit pas excéder 120°F. Au Massachusetts, la température de sortie maximale du robinet de douche ne doit pas excéder 112°F.
- Conservez ce livret et le reçu (ou une autre preuve sur laquelle figurent la date et l'endroit de l'achat) pour ce produit dans un endroit sûr. Le reçu est requis si vous commandez des pièces sous garantie.

Datos técnicos

Presión recomendada en servicio	15 - 75 PSI
Presión en servicio max.	145 PSI
Temperatura recomendada del agua caliente	120° - 140° F*
Temperatura del agua caliente max.	176° F*
Caudal máximo - ducha cabezal	2.0 GPM
Caudal máximo - teleducha	2.0 GPM

*Debe conocer y cumplir todos los códigos locales aplicables para ajustar la temperatura del calentador de agua.

Consideraciones para la instalación

- Para obtener mejores resultados, la instalación debe estar a cargo de un plomero profesional matriculado.
- Antes de comenzar la instalación, lea estas instrucciones detenidamente. Asegúrese de tener las herramientas y los insumos necesarios para completar la instalación.
- **Esta unidad debe instalarse con un juego básico 16181181 (no incluido).**
- Para garantizar el funcionamiento duradero del termostato, el mando del mismo debería girarse de vez en cuando del extremo frío al extremo caliente.
- El termostato está equipado con válvula, la cual evita el retorno del agua a la tubería. Las válvulas anti-retorno tienen que ser controladas regularmente en acuerdo con las regulaciones nacionales o regionales (una vez al año, por lo menos).
- Para evitar escaldaduras, la máxima temperatura de salida de la válvula de la ducha no debe exceder los 120°F. En Massachusetts, la máxima temperatura de salida de la válvula de la ducha no debe exceder los 112°F.
- Mantenga este folleto y el recibo (u otro comprobante del lugar y fecha de compra) de este producto en lugar seguro. El recibo se requiere en caso de ser necesario solicitar piezas bajo garantía.

Tools Required / Outils Utiles / Herramientas Utiles

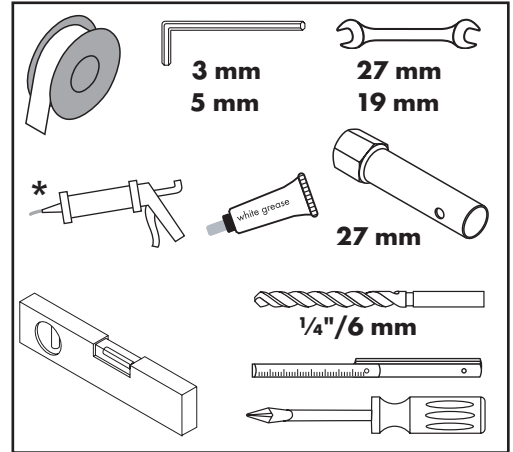

- * Select a sealant that is safe for use on glass.
- * Choisissez un agent d'étanchéité qui est sûr pour l'usage sur le verre.
- * Seleccione un sellador que está a salvo para uso en el vidrio.

- ! **This automatic compensating valve is for use with showerheads rated at 1.5 GPM (5.7 L/min) or higher.**
- ! **Cette soupape qui compense automatiquement doit être utilisée avec les pommes de douche évaluées à 1,5 GPM (5,7 L/min.) ou plus.**
- ! **Esta válvula que compensa automáticamente es debe ser utilizada con duchas valoradas en 1,5 GPM (5,7 L/min) o más.**

Installation Suggestions / Suggestions d'installation / Sugerecias para la instalaci3n

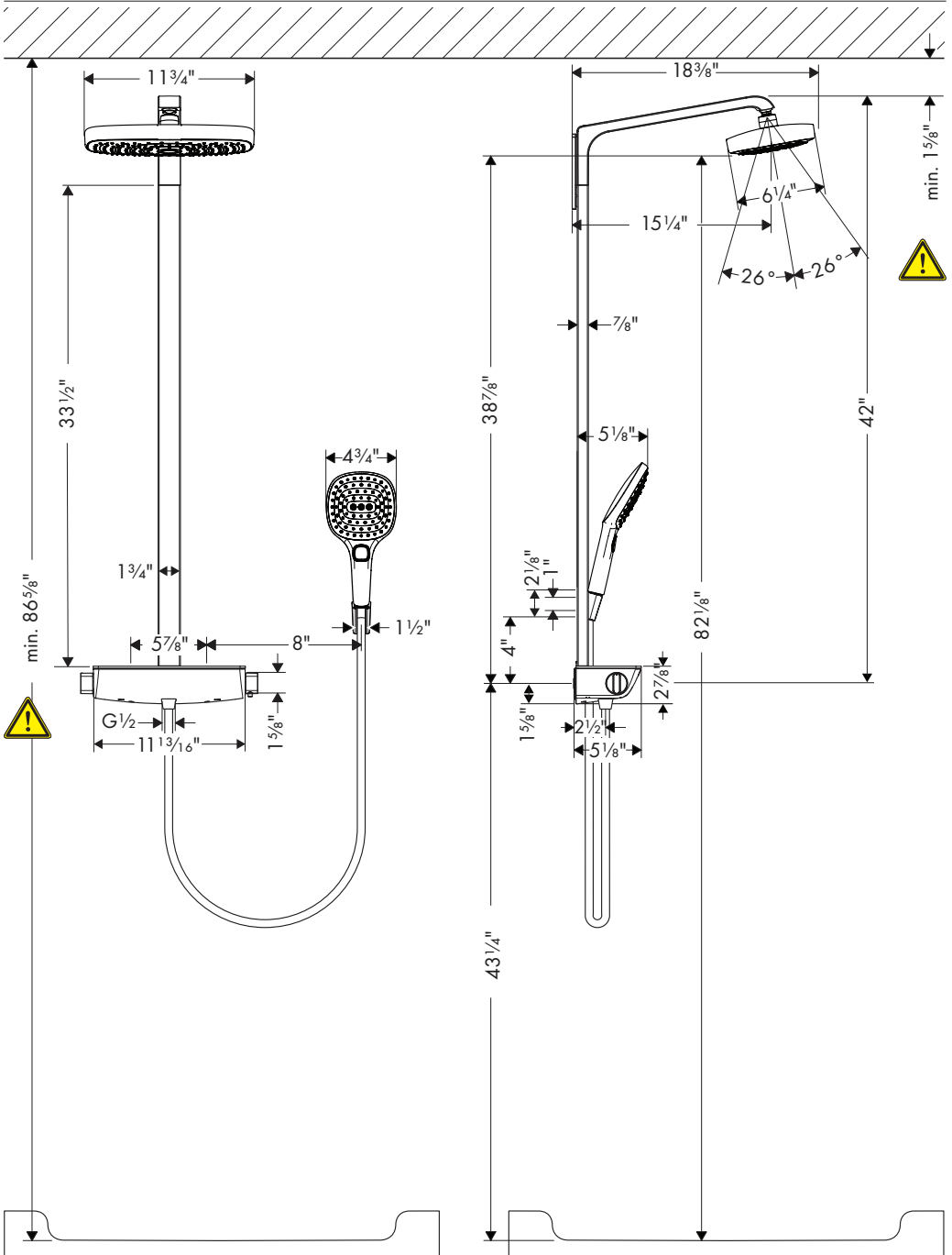

Installation / Installation / Instalación

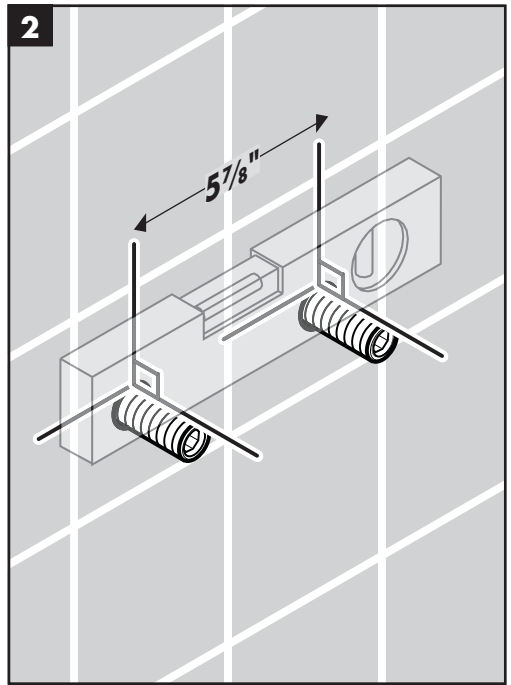
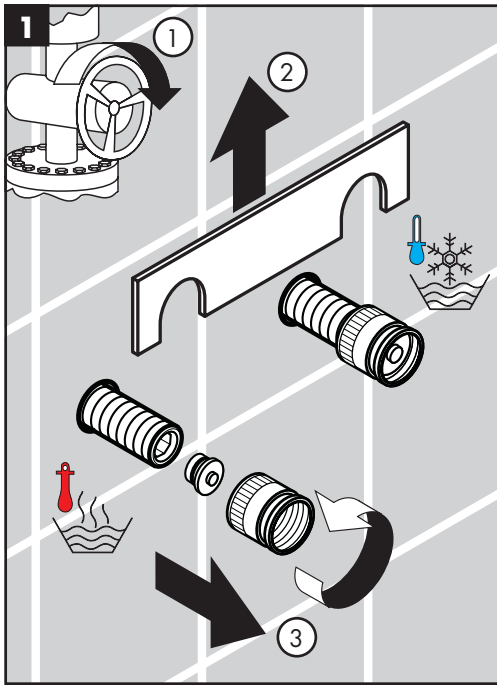

English

The showerpipe must be installed with showerpipe rough set 16181181 (not included).

! To insure correct operation of the thermostatic mixing valve, the hot supply must be on the left and the cold supply must be on the right.

Turn the water off at the main.

Remove the spacing jig, nuts, and plugs.

Confirm that the nipples are level in all planes and are parallel to each other.

Français

Le showerpipe doit être installé avec l'ensemble de pièce intérieure pour tuyau de douche 16181181 (non inclus).

! Pour vous assurer que le mélangeur thermostatique fonctionne correctement, installez la conduite d'eau chaude à gauche et la conduite d'eau froide à droite.

Fermez l'eau à la valve principale.

Retirez le gabarit d'espacement, les écrous et les bouchons.

Assurez-vous que les raccords filetés sont au niveau sur tous les plans et installés de manière parallèle.

Español

El showerpipe debe ser instalado con un juego de piezas interiores del tubo de ducha 16181181 (no incluido).

! Para que la válvula mezcladora termostática funcione correctamente, el suministro de agua caliente debe estar a la izquierda y el de agua fría a la derecha.

Cierre el paso del agua en la entrada del suministro.

Retire la plantilla espaciadora, las tuercas y los tapones.

Confirme que los nipples estén nivelados en todos los planos y paralelos entre sí.

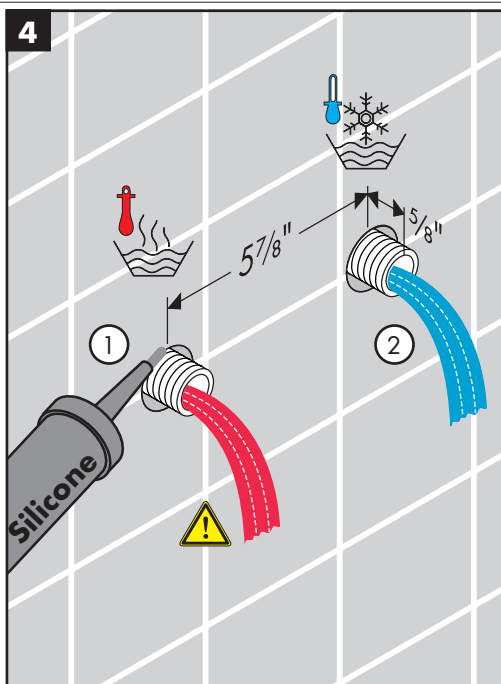
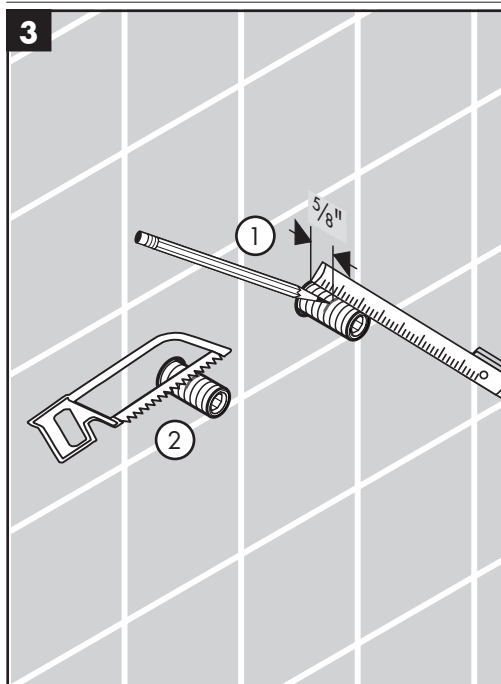

English

Mark a point on each nipple $\frac{5}{8}$ " from the surface of the finished wall

Carefully cut the nipple at this point.

! Seal the wall around the nipples with water-proof sealant.

Flush the hot and cold supplies thoroughly

Damage to the Raindance Select caused by debris is not covered by the Hansgrohe warranty.

Français

Faites une marque sur chaque raccord fileté à $\frac{5}{8}$ po de la surface du mur fini.

Coupez soigneusement le raccord fileté sur cette marque.

! Scellez le mur autour des raccords filetés à l'aide d'un agent d'étanchéité.

Rincez bien les conduites d'alimentation d'eau chaude et d'eau froide.

Les dommages causés au Raindance Select par les débris ne sont pas couverts par la garantie de Hansgrohe.

Español

Marque un punto en cada niple de $\frac{5}{8}$ " desde la superficie de la pared terminada.

Corte cuidadosamente el niple en este punto.

! Selle la pared alrededor de los nipples con un sellador impermeable.

Lave a fondo los suministros frío y caliente

Los daños al Raindance Select causados por residuos no están cubiertos por la garantía de Hansgrohe.

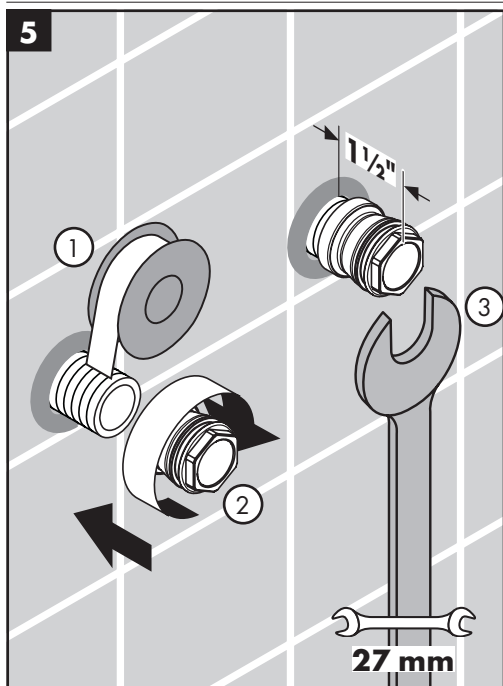

English

Wrap the nipples with plumbers' tape.

Install the adapters.

⚠ Over-tightening the adapters may cause damage to the adapters or to the nipples.

The adapters should extend 1 1/2" outside the surface of the finished wall.

Use the spacing jig to confirm that the adapters are positioned correctly and are level.

Français

Enveloppez les raccords filetés avec du ruban de plombier.

Installez les adaptateurs.

⚠ Le fait de serrer excessivement les adaptateurs pourrait endommager ces derniers ou les raccords filetés.

Les adaptateurs doivent dépasser de 1 1/2 po de la surface du mur fini.

Utilisez le gabarit d'espacement pour vous assurer que les adaptateurs sont positionnés correctement et au niveau.

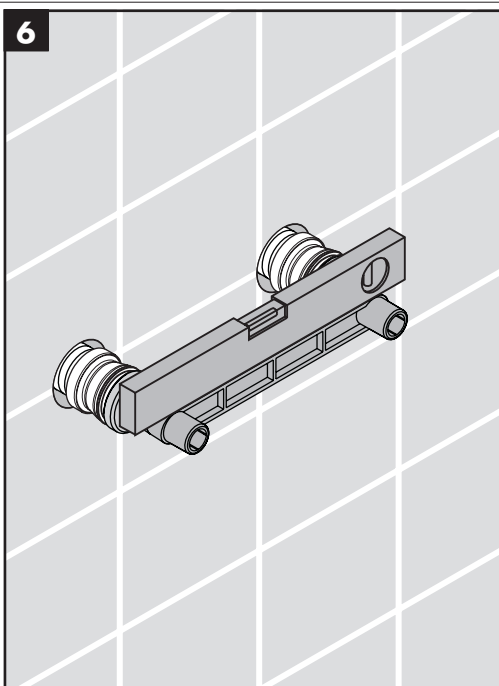

Español

Envuelva los nipples con cinta de plomero.

Instale los adaptadores.

⚠ El ajuste excesivo de los adaptadores podría provocar daños a los adaptadores o a los nipples.

Los adaptadores deben sobresalir 1 1/2" de la superficie de la pared terminada.

Use la plantilla espaciadora para confirmar que los adaptadores estén bien colocados y nivelados.

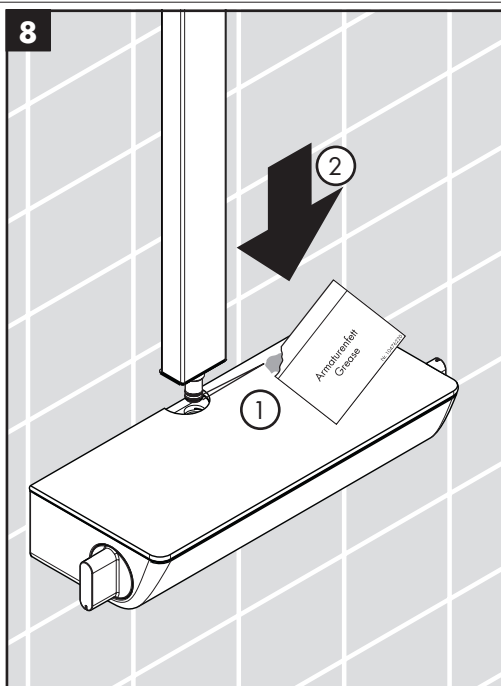
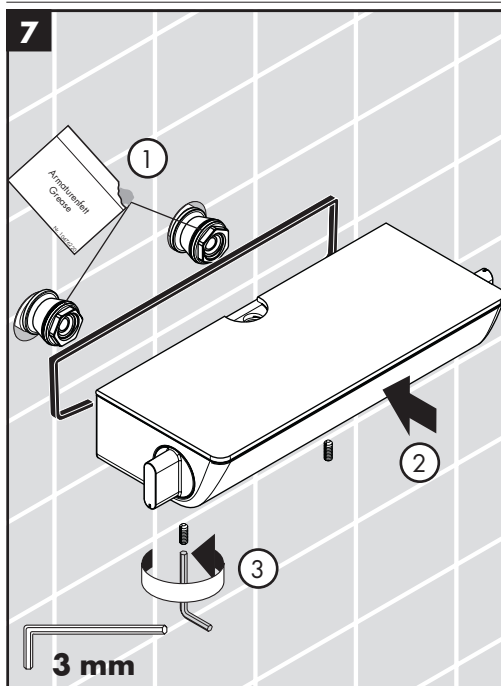

English

Lightly lubricate the adapter o-rings using white plumber's grease.

Install the mixer.

Tighten the screws

⚠ Overtightening the screws will result in product damage.

Lubricate the bottom riser o-ring.

Install the riser on the mixer.

Français

Lubrifiez légèrement les joints sur l'adaptateur en utilisant de la graisse de plomberie blanche.

Installez le mélangeur thermostatique.

Serrez les vis.

⚠ Ne serrez pas les vis excessivement car vous pourriez endommager le produit.

Lubrifiez légèrement les joints sur le tuyau en utilisant de la graisse de plomberie blanche.

Installez la tuyau sur le mélangeur.

Español

Lubrique levemente las juntas del adaptador con grasa blanca para plomería.

Instale la mezcladora termostática.

Apriete los tornillos.

⚠ No apriete excesivamente los tornillos ya que puede dañar la unidad.

Lubrique ligeramente las juntas sobre el tubo con grasa blanca para plomería.

Instale tubo sobre el mezclador.

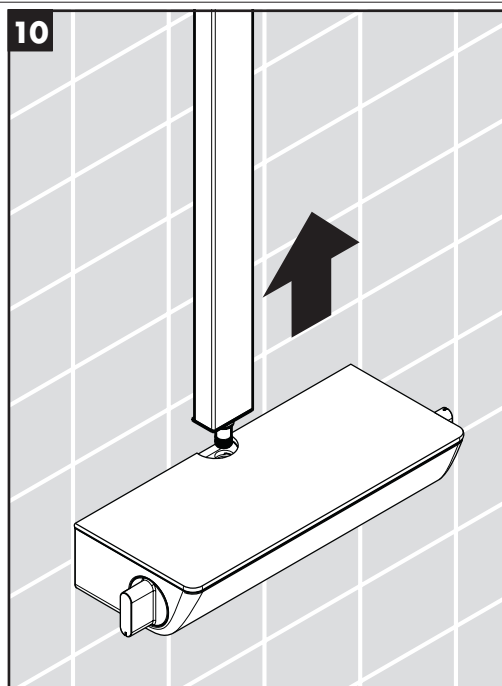
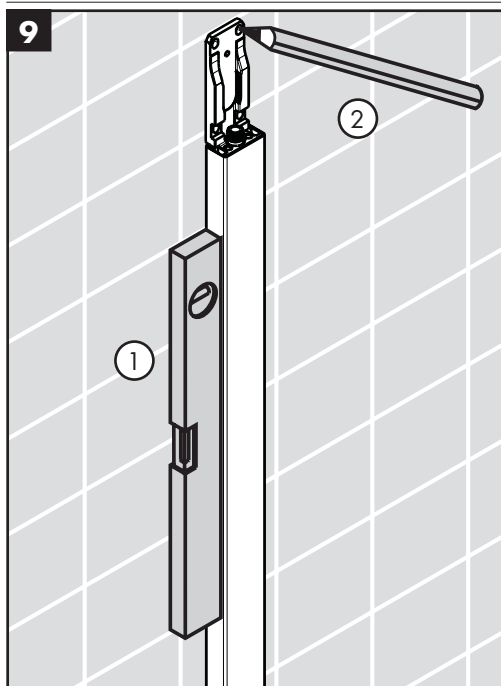

English

Make sure that the riser is level.
Mark the positions of the screw holes.

Français

Veillez à ce que la tuyau soit au niveau.
Marquez les positions des quatre trous de vissage.

Español

Verifique que el tubo quede nivelada..
Marque las posiciones de los orificios para tornillos.

Remove the riser.

Enlevez la tuyau.

Quite el tubo.

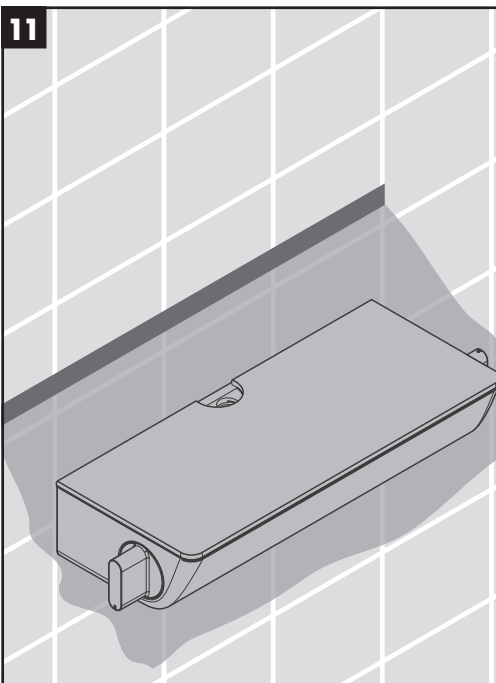

English

Protect the mixer with a plastic sheet.

Hold the handshower holder against the wall at the desired location.

Mark the positions of the screws.

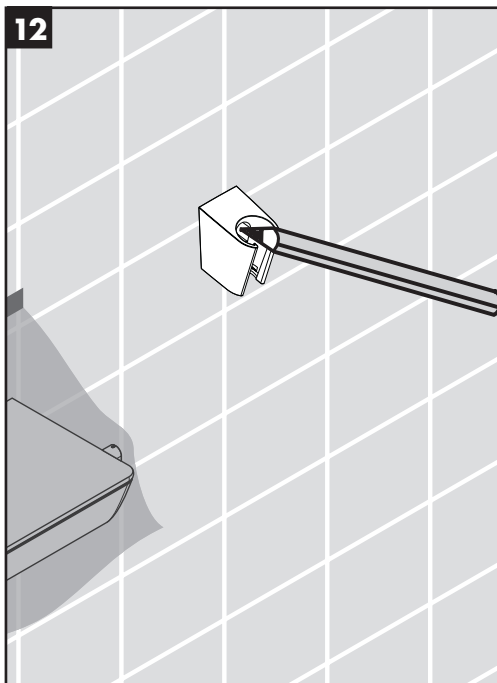

Español

Proteja el mezclador que utiliza una hoja de plástico.

Coloque el soporte de la ducha cabezal sobre la superficie de montaje.

Marque las posiciones de los orificios para tornillos.

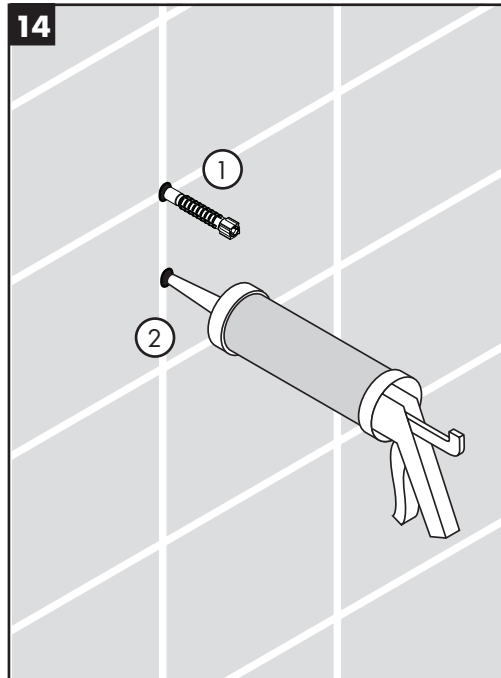
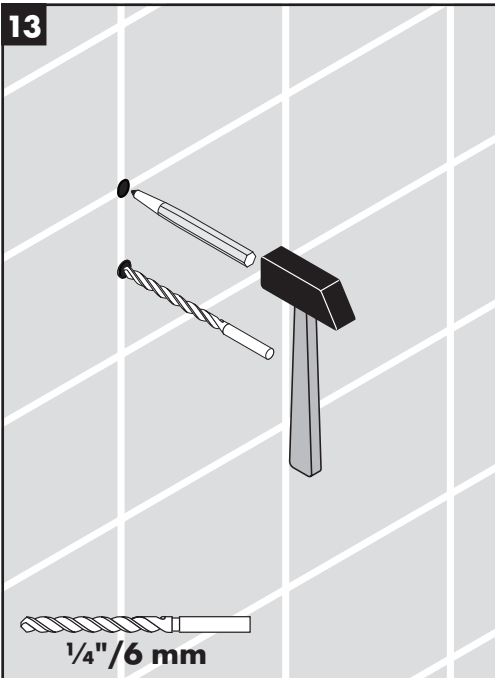

English

Drill the holes.

Français

Percez les trous.

Español

Perfore los orificios para tornillos.

Install the anchors.



Seal the wall around the anchors using waterproof sealant.



Scellez le mur autour des chevilles à l'aide d'un agent d'étanchéité.



Selle la pared alrededor de los pernos de anclaje con un sellador impermeable.



Failure to seal the wall may result in water damage.



Si le mur n'est pas scellé, l'eau pourrait éventuellement causer des dommages.



Si no se sella la pared, pueden producirse daños por acción del agua.

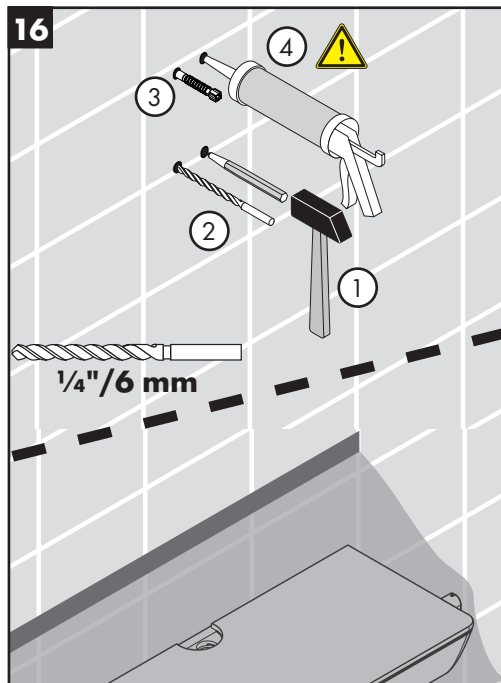
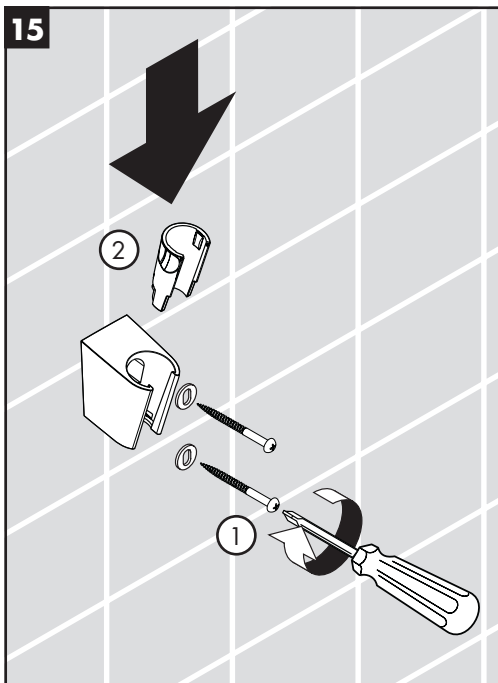

English

Install the handheld shower holder.

Français

Installez le support de douche.

Español

Instale el soporte de ducha.

Drill the screw holes for the shower pipe mounting piece.

Percez les trous pour la pièce de montage.

Perfore los orificios para tornillos.

Install the anchors.

Installez les chevilles.

Instale los pernos de anclaje.

! Seal the wall around the anchors using waterproof sealant.

! Scellez le mur autour des chevilles à l'aide d'un agent d'étanchéité.

! Selle la pared alrededor de los pernos de anclaje con un sellador impermeable.

! Failure to seal the wall may result in water damage.

! Si le mur n'est pas scellé, l'eau pourrait éventuellement causer des dommages.

! Si no se sella la pared, pueden producirse daños por acción del agua.

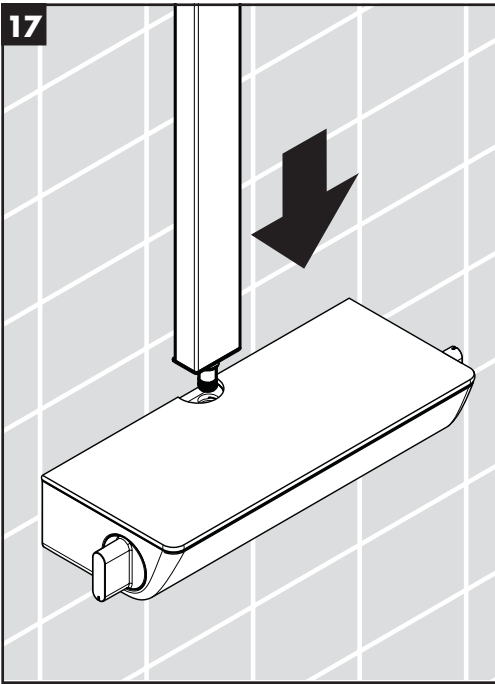

English

Install the riser on the mixer.

Install the screws.

Français

Installez la tuyau sur le mélangeur thermostatique.

Installez les vis.

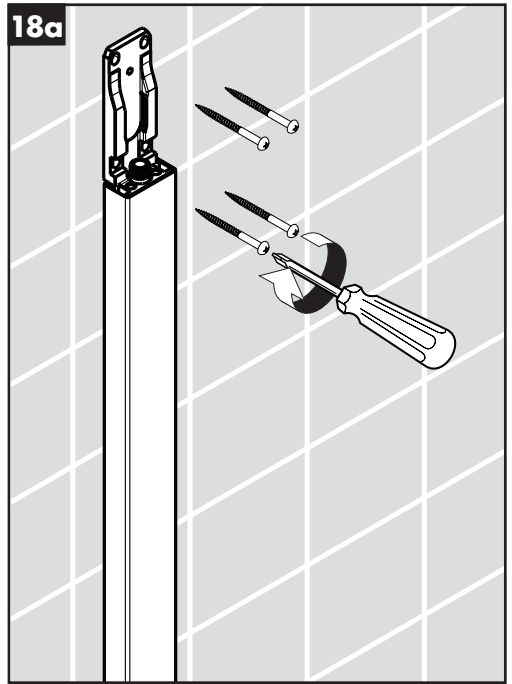

Español

Instale el tubo sobre el mezclador thermostatique.

Instale los tornillos.

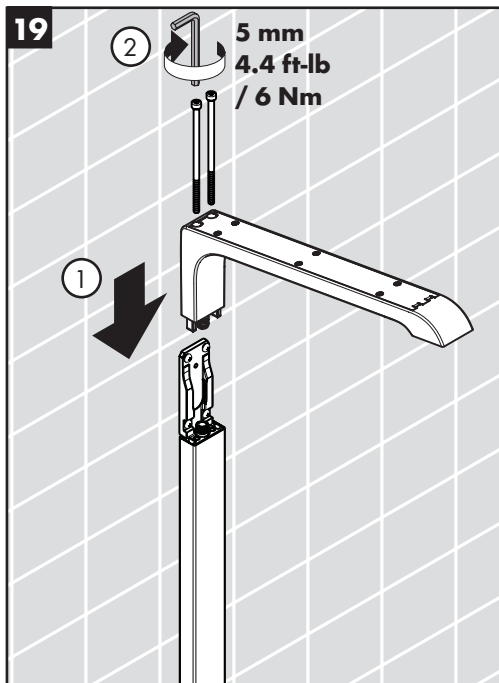
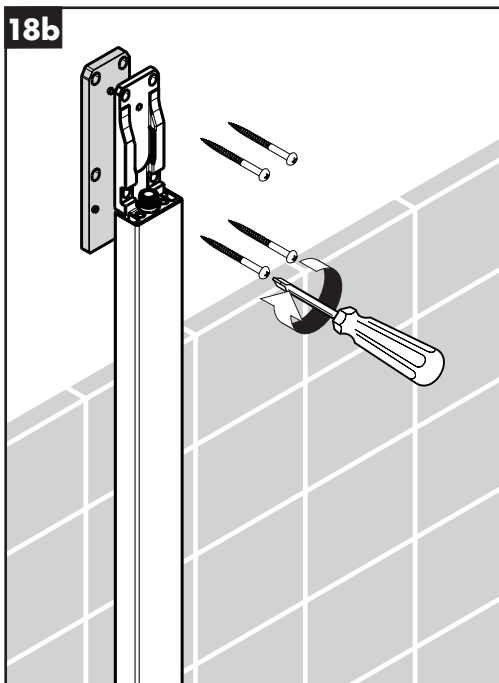

English

Français

Español

OR

If the tile does not go all the way up the wall, use the tile spacer.

OU

Si les carreaux ne couvrent pas la surface jusqu'au plafond, installez la plaque de montage avec le disque adaptateur.

O

Si el azulejo no va hasta arriba de la pared, instale la placa de montaje con el disco que coincide con el azulejo.

Install the shower arm.



Do not over-tighten the screws.



Installez le bras de douche.

Ne serrez pas les vis excessivement.



Instale el brazo de ducha.

No apriete los tornillos excesivamente.



Over-tightening the screws may result in product damage.

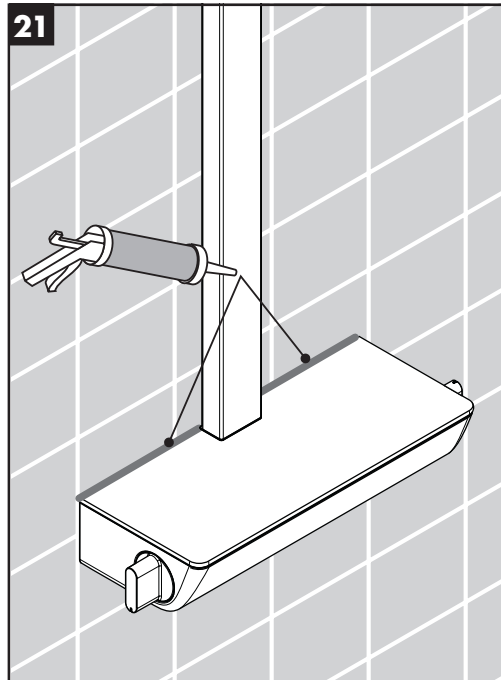
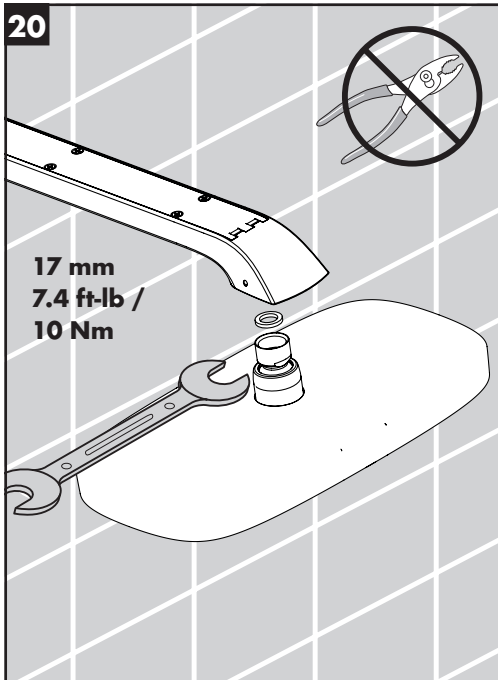

English

Install the showerhead.

Français

Installez le pomme de douche

Español

Instale la ducha cabezal.

Seal the gap between the top of the mixer and the wall.

 **Select a sealant that is safe for use on glass.**

Scellez le mur autour de la partie supérieure du produit à l'aide d'un agent d'étanchéité.

 **Choisissez un agent d'étanchéité qui est sûr pour l'usage sur le verre.**

Selle la pared alrededor de la parte superior del producto con la ayuda de un agente de impermeabilidad.

 **Seleccione un sellador que está a salvo para uso en el vidrio.**

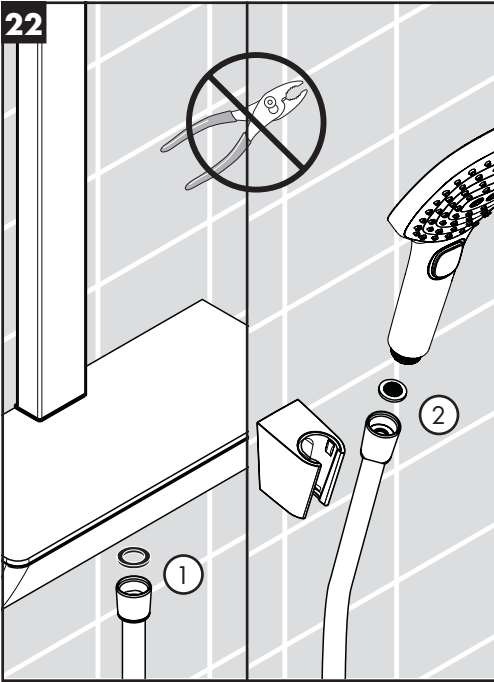
22**English**

Place the hose washer in the short hose end connection.

Connect this end of the hose to the mixer.

Place the screen washer in the long hose end connection.

Install the handshower on this end of the hose.

Rest the handshower in the holder.

Français

Placez la rondelle de tuyau en caoutchouc noir dans l'une des extrémités du tuyau.

Vissez cette extrémité du tuyau à la sortie pour douchette sur la valve.

Placez le tamis dans l'autre extrémité du tuyau. Vissez cette extrémité à la douchette.

Placez la douchette dans son support.

Español

Coloque la arandela de la manguera en un extremo de esta.

Enrosque este extremo a la salida de la ducha de mano.

Coloque la arandela de filtro en el otro extremo y conéctelo a la ducha de mano.

Coloque la ducha de mano en el soporte.

Set the High Temperature Limit Stop (optional) / Réglage de la butée limite d'eau chaude (en option) / Ajuste el tope de límite de alta temperatura (opcional)

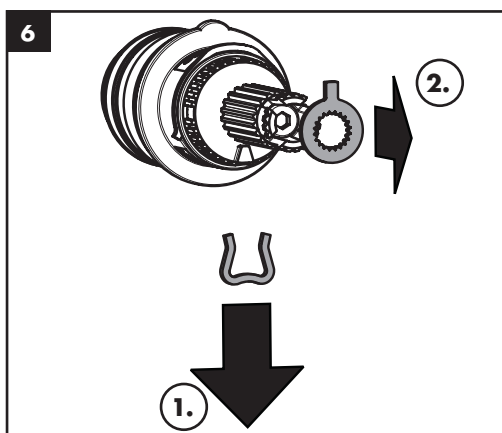
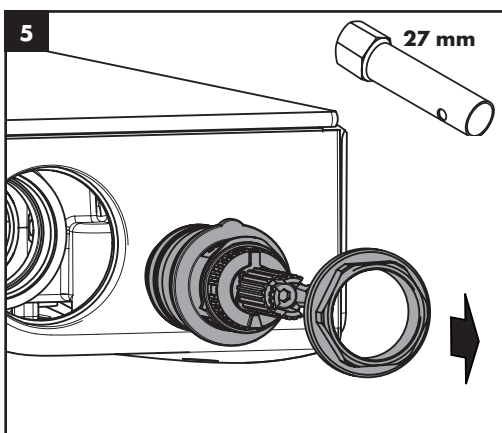
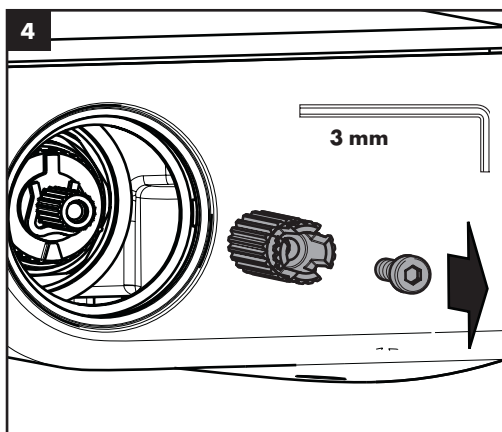
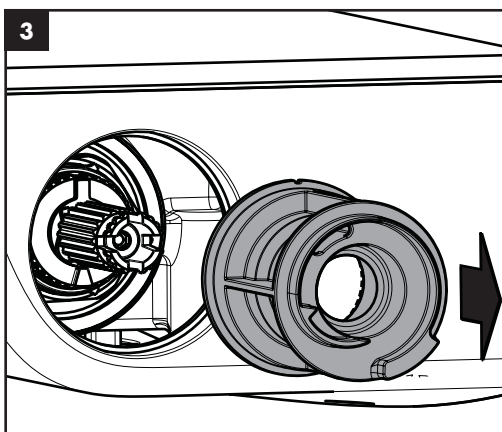
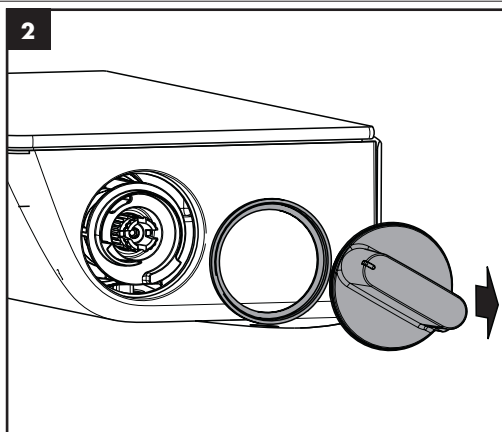
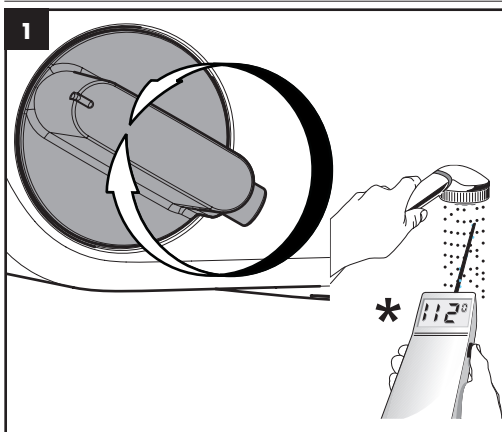

Set the High Temperature Limit Stop (optional) / Réglage de la butée limite d'eau chaude (en option) / Ajuste el tope de límite de alta temperatura (opcional)

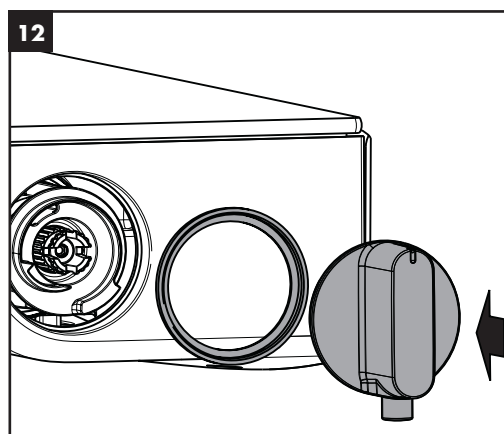
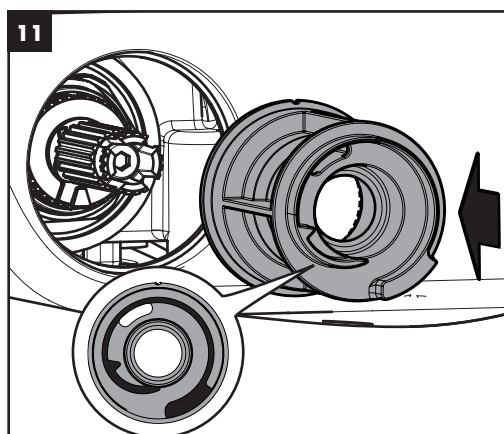
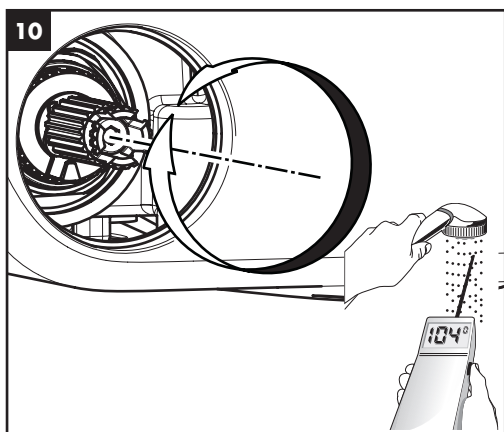
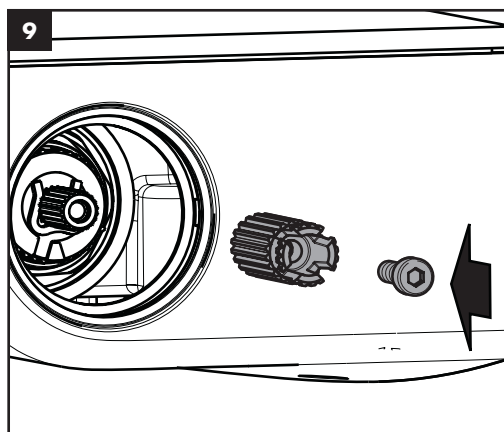
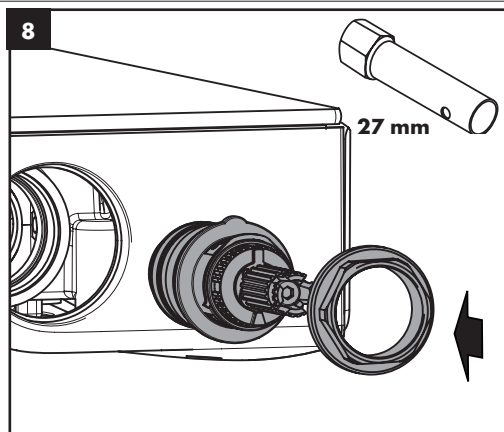
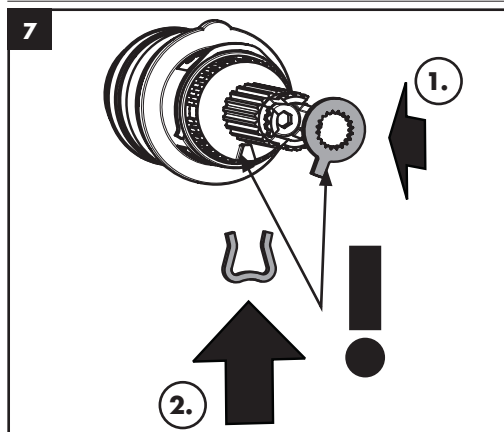

Replacement Parts / Pièces détachées / Repuestos

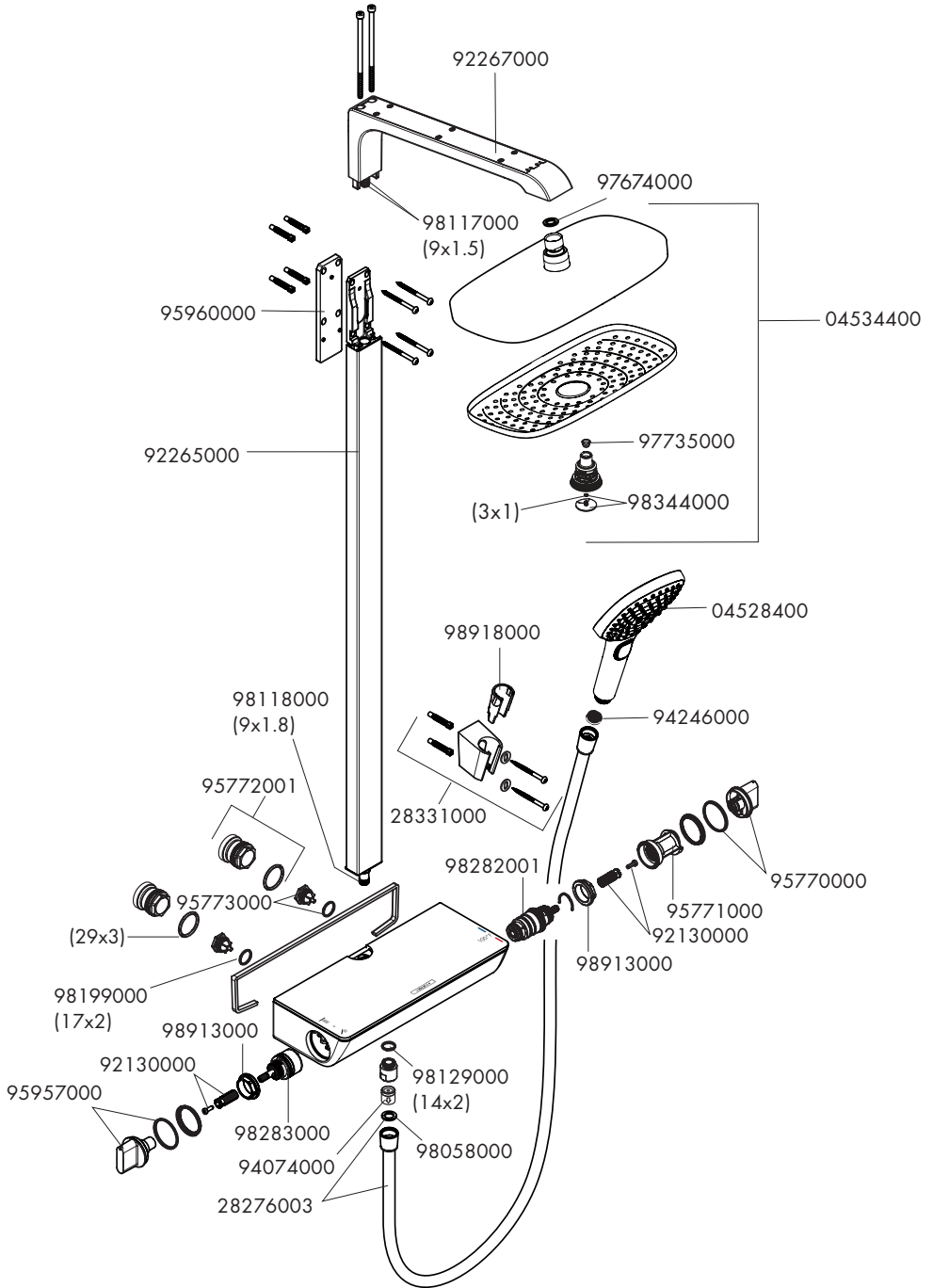

User Instructions / Instructions de service / Manejo

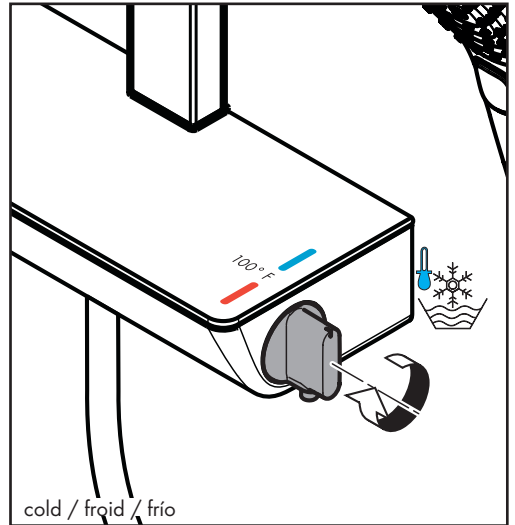
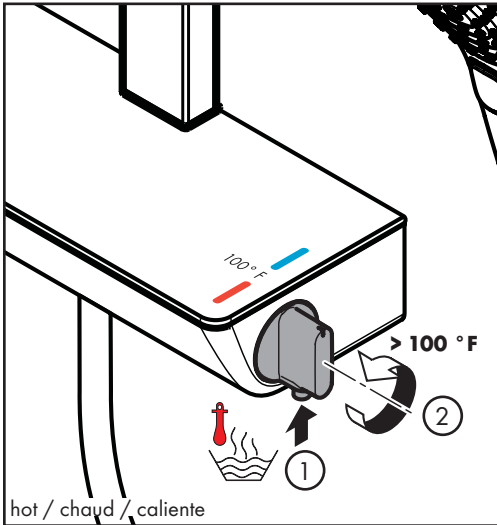
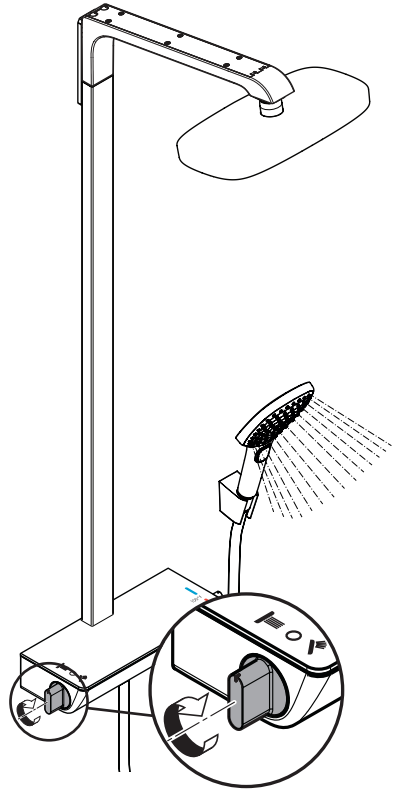
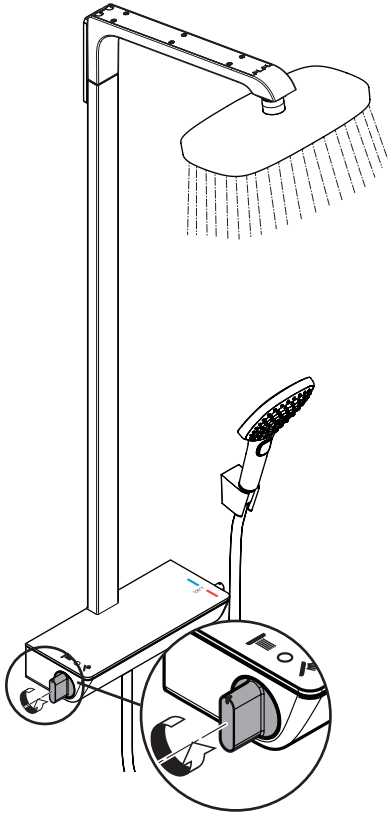

Rain

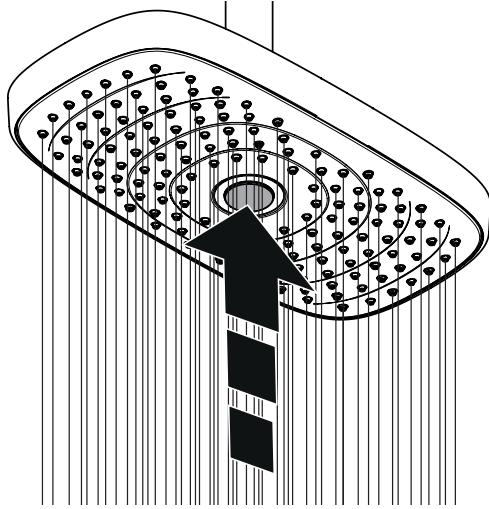

RainAir

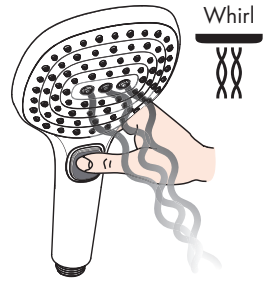
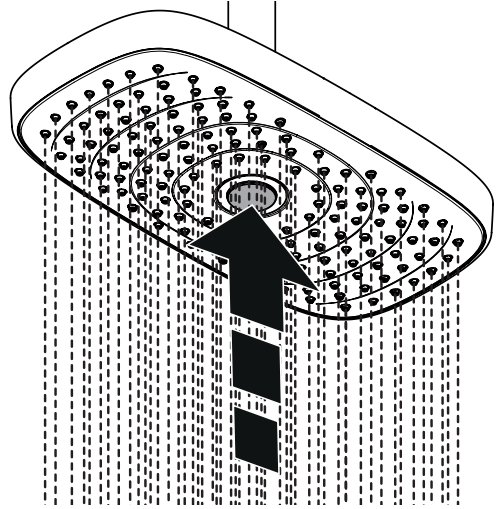

Cleaning / Nettoyage / Limpeza

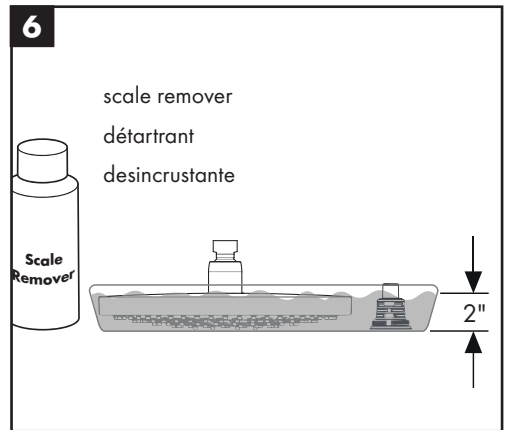
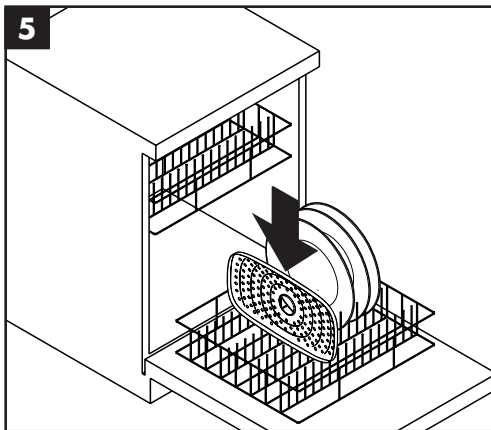
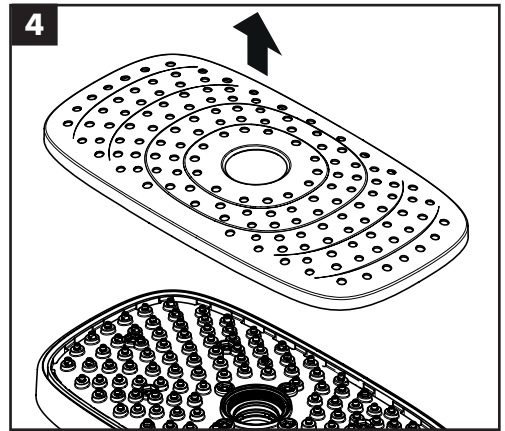
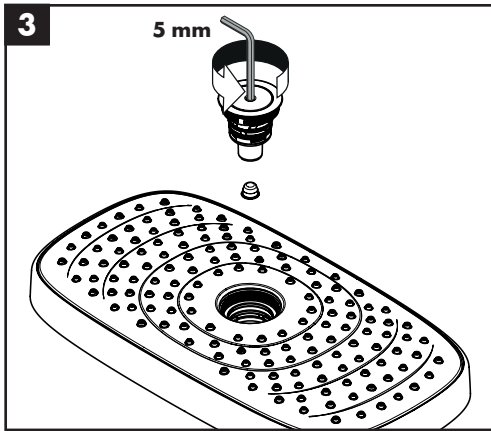
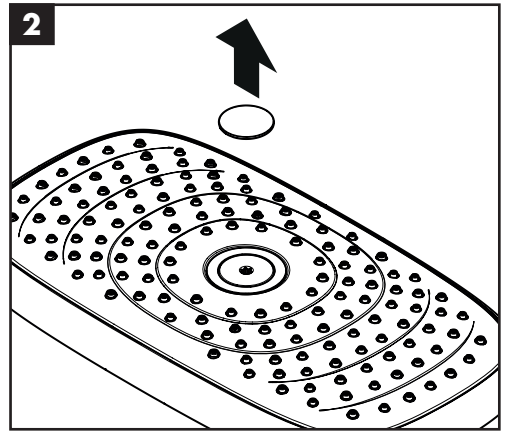
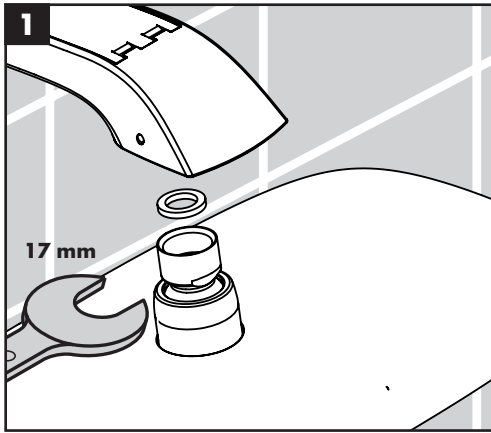

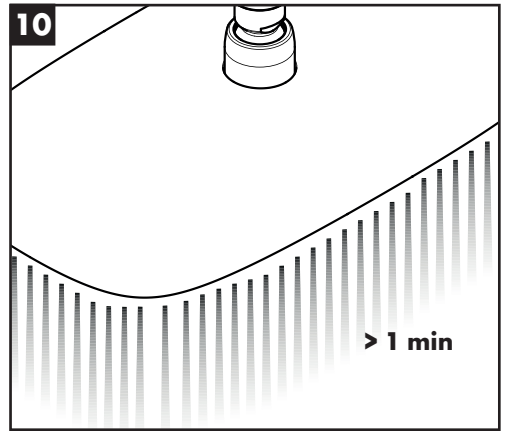
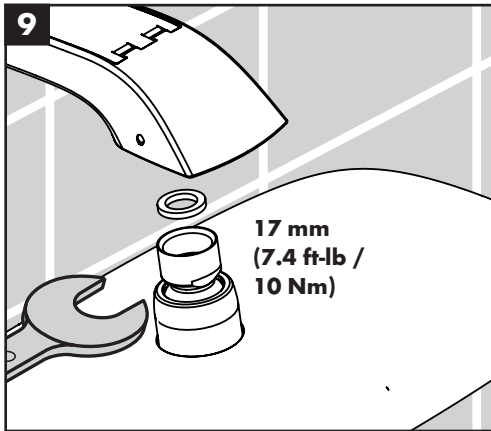
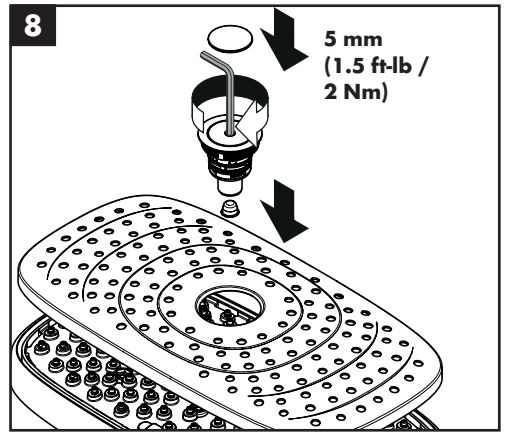
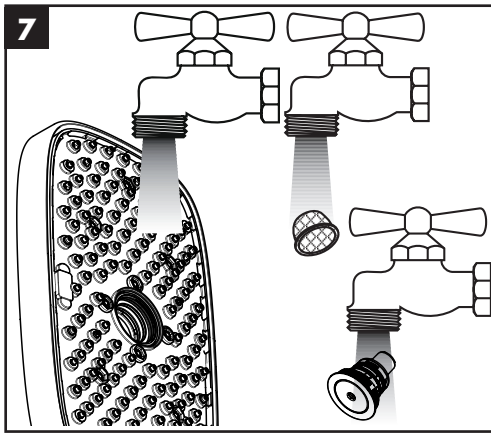

Maintenance / Entretien / Mantenimiento

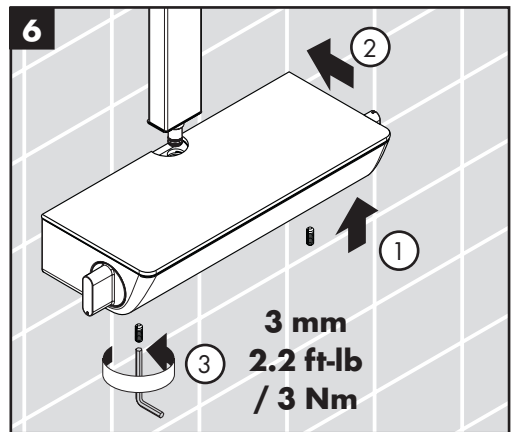
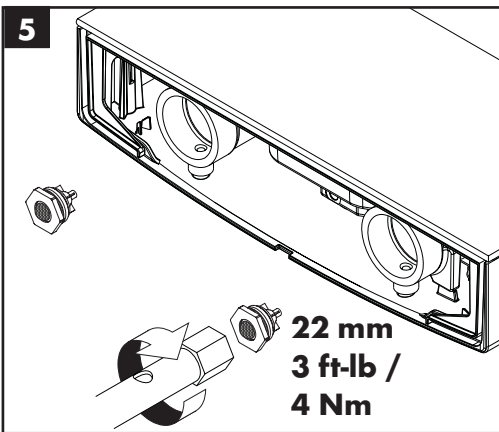
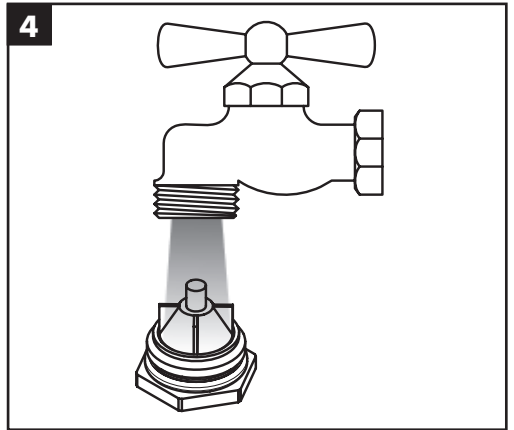
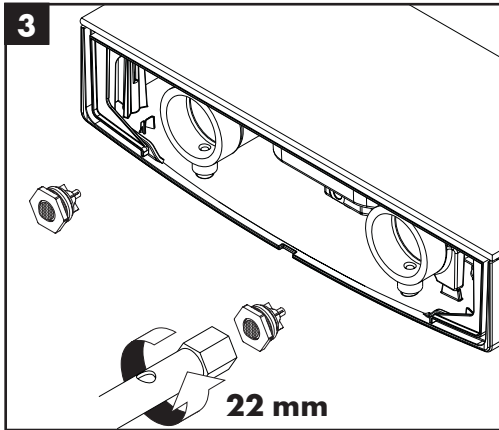
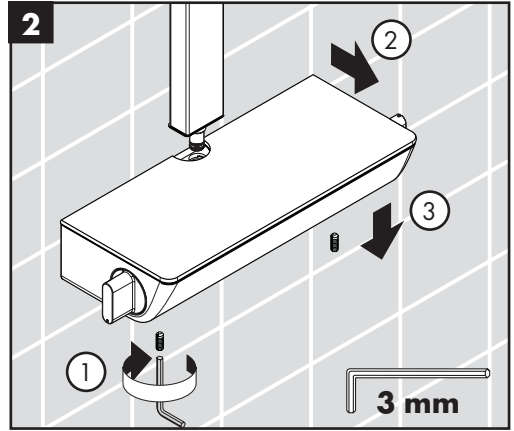
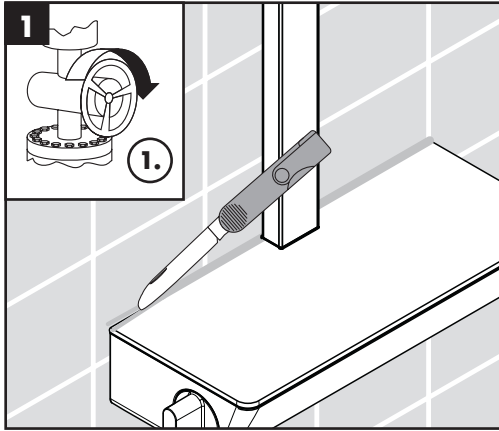

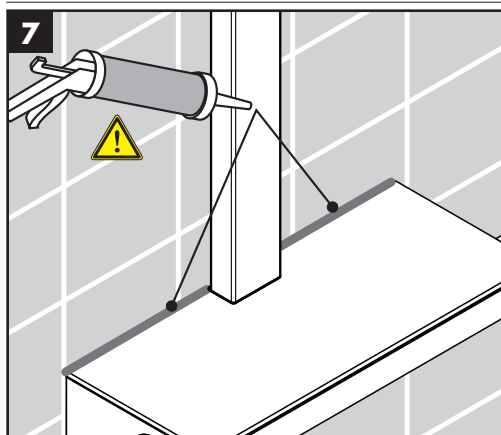

 Select a sealant that is safe for use on glass.

 Choisissez un agent d'étanchéité qui est sûr pour l'usage sur le verre.

 Seleccione un sellador que está a salvo para uso en el vidrio.

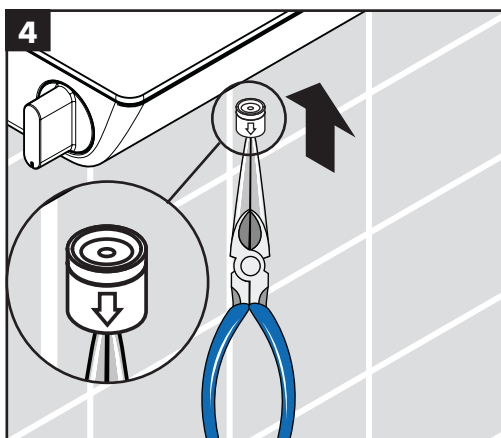
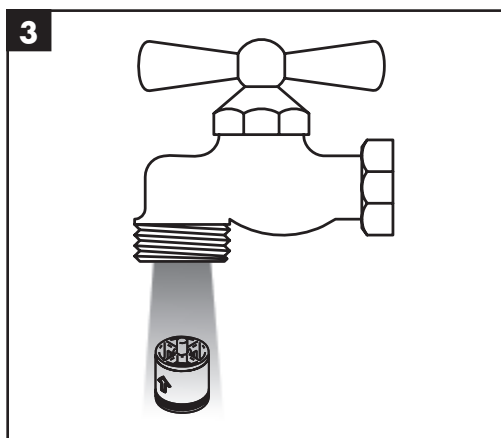
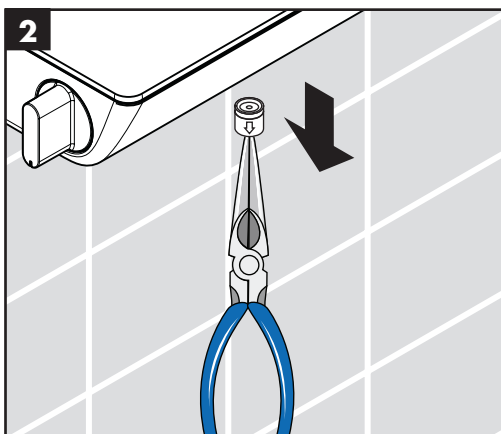
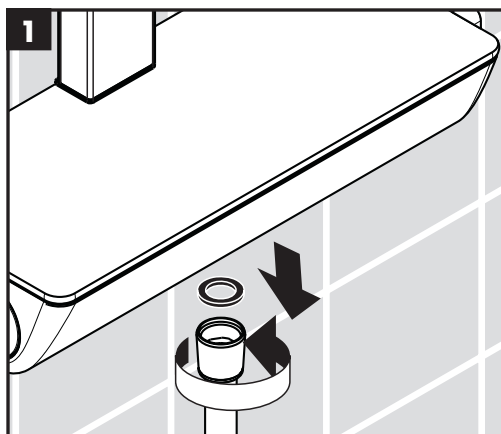

Troubleshooting

Problem	Possible Cause	Remedy
Insufficient water	Supply pressure inadequate	Check water pressure (If a pump has been installed check to see if the pump is working).
	Filters are dirty	Clean filter in front of the mixer and on the thermostatic cartridge
	Shower filter seal dirty	Clean filter seal between handshower and hose
Crossflow, hot water being forced into cold water pipe, or vice versa, when mixer is closed	Check valves dirty or worn	Clean check valves, exchange if necessary
Spout temperature does not correspond with temperature set	Handle not justified	Justify the handle
	Hot water temperature too low	Increase hot water temperature to 120 °F to 140 °F
Temperature regulation not possible	thermo cartridge worn	Replace thermo cartridge
Mixer outputs both hot and cold water, but not mixed	Not a product problem - hot and cold supplies are reversed	Correct the plumbing
Handshower dripping	Shut-off cartridge dirty or worn	Clean or replace shut-off cartridge
Instantaneous heater didn't work with thermostat	Filters are dirty	Clean or replace the filters
	Check valve is dirty or worn	Clean or replace the check valves

Dépannage

Dysfonctionnement	Origine	Solution
Pas assez d'eau	Pression d'alimentation insuffisante	Contrôler la pression
	Filtres encrassés	Nettoyer les filtres devant le mitigeur thermostatique et sur la cartouche
	Joint-filtre de douchette encrassé	Nettoyer le joint-filtre entre la douchette et le flexible
Circulation opposée, l'eau chaude est comprimée dans l'arrivée d'eau froide et vice versa avec robinet fermé	Clapet anti-retour encrassé ou défectueux	Nettoyer le clapet anti-retour ou le changer éventuellement
La température à la sortie ne correspond pas à la température de réglage	Le thermostat n'a pas été réglé	Régler le thermostat
	Température d'eau chaude trop basse, pas d'eau froide	Augmenter la température d'eau chaude entre 42°C et 65°C
Le réglage de la température n'est pas possible	Cartouche thermostatique entartrée	Changer la cartouche thermostatique

La douchette ou le bec verseur goutte	De la saleté ou de l'incrustation sur le siège, mécanisme d'arrêt défectueux	Nettoyez le mécanisme d'arrêt ou le changez éventuellement
Le chauffe-eau instantané ne s'allume pas lors de l'utilisation du thermostat	Bague de butée non démontée	Démontez la bague de butée (95771000)
	Réducteur de débit non démonté	Démonter le réducteur de débit de la douchette
	Filtres encrassés	Nettoyez / changez les filtres
	Clapet anti-retour bloqué	Changez le clapet antiretour

Localización de fallas

Problema	Causa	Solución
Sale poca agua	presión insuficiente	comprobar presión
	filtro de la ducha sucio	limpiar filtro entre flexo y ducha
	filtro de la ducha sucio	limpiar/cambiar filtros entre flexo y ducha
Flujo de agua cruzada agua caliente entra en la tubería del agua fría o al revés	válvula antirretorno sucia o pierde	limpiar / cambiar válvula
Temperatura del agua no corresponde a lo marcado	termostato no ha sido ajustado	ajustar termostato
	temperatura del agua demasiado baja no hay	aumentar temperatura del agua caliente a 42° - 65° C.
No es posible regular la temperatura	termoelemento calcificado	cambiar termoelemento
Llave de paso pierde agua	suciedad/cal en el asiento de la junta o montura dañada	limpiar / cambiar montura
Calentador instantáneo no se enciende en combinación con el termostato	anillo de tope Ecostop aún montado	quitar tope de caudal (95771000)
	no se ha quitado limitador de caudal de la teleducha	quitar limitador de caudal
	filtro de la ducha sucio	limpiar/cambiar filtros
	válvula anti-retorno cerrada	cambiar válvula anti-retorno

Cleaning Recommendation for Hansgrohe Products

Modern bathroom faucets, kitchen faucets and shower products are made from different materials to comply with the needs of the market with regard to design and functionality. To avoid damage to the product, it is necessary to take proper care of it.

For best results:

- Prevent the buildup of mineral scale and /or soap residue by cleaning your Hansgrohe product(s) when needed.
- Select a cleaning agent specifically intended for the type of product.
- **Do not** use these types of cleaners as they will cause damage to your Hansgrohe product:
 - ✗ Any cleaning agent containing hydrochloric acid, formic acid, lye, or acetic acid.
 - ✗ Abrasive cleaning powders, pads, or brushes.
 - ✗ Steam cleaners.
 - ✗ "No rinse" cleaning agents.
- **Always** follow the instructions provided by the manufacturer of the cleaning agent.
- **Do not** mix cleaning agents, unless directed by the manufacturer.
- **Do not** spray cleaners directly onto the product as drops could enter openings and gaps and cause damage. When using spray cleaners, spray the cleaner onto a soft cloth or sponge.
- **Always** rinse your Hansgrohe product thoroughly with clear water and polish dry with a soft cloth after cleaning.

Important

- Residue from soaps, shampoos, hair dye, and other toiletries and cosmetics can cause damage. Rinse the product with clean water after each use.
- Residue from basin/tub/tile cleaner can cause damage to faucets and fittings. Immediately rinse any overspray from the Hansgrohe product.
- Do not store any cleaning agents under your Hansgrohe product, such as in a vanity unit, as the fumes may damage the product.
- **Damage to the product caused by improper care or the use of improper cleaning agents is not covered by the warranty.**
- **If a component of the product is damaged, replace it, as there is risk of injury.**

Conseil de nettoyage pour les produits Hansgrohe

Les robinets pour les salles de bains et les cuisines modernes ainsi que les produits récents pour les douches se composent de matériaux différents afin de satisfaire aux besoins du marché en termes de conception et de fonctionnalité. Afin d'éviter d'endommager le produit, il est nécessaire d'en prendre soin.

Pour de meilleurs résultats :

- Empêchez l'accumulation de tarte et/ou de résidu de savon en nettoyant votre produit Hansgrohe lorsque c'est nécessaire.
- Sélectionnez un produit de nettoyage spécifiquement prévu pour ce type de produit.
- **N'utilisez pas** ces types de nettoyeurs car ils peuvent endommager votre produit Hansgrohe :
 - ✗ Tout produit de nettoyage contenant de l'acide chlorhydrique, de l'acide formique, de la potasse ou de l'acide acétique.
 - ✗ Les poudres de nettoyage, les tampons ou les brosses abrasives.
 - ✗ Les nettoyeurs à vapeur.
 - ✗ Les produits de nettoyage « sans rinçage ».
- **Ne mélangez pas** les produits de nettoyage, à moins que cela soit indiqué par le fabricant.

-
- **Ne pulvérisez pas** los nettoyants directement sur le produit car des gouttes pourraient entrer dans les ouvertures et les fentes et causer des dommages. Lorsque vous utilisez des nettoyants par pulvérisation, pulvérisez le nettoyant sur un chiffon ou une éponge douce.

Important

- Les résidus de produits pour le corps comme les savons liquides, shampoings, gels de douche, teintures pour cheveux, parfums, après-rasage et vernis à ongles peuvent causer des détériorations. Rincez le produit avec de l'eau propre après chaque utilisation.
- Le résidu provenant des nettoyants pour cuvette/baignoire/carrelage peut endommager les robinets et les raccords de tuyauterie. Rincez immédiatement toute surpulvérisation sur le produit Hansgrohe.
- De même, il est interdit de stocker des détergents ou des produits chimiques sous les produits, par ex. dans un meuble sous lavabo, car les vapeurs qui s'en dégagent risquent d'abîmer les produits.
- **Les dommages au produit causés par un mauvais entretien ou par l'utilisation de produits de nettoyage inadéquats ne sont pas couverts par la garantie.**
- **Si un composant du produit est endommagé, remplacez-le, car il existe un risque de blessure.**

Recomendación de limpieza para los productos de Hansgrohe

Hoy en día, las griferías de baño y de cocina así como duchas modernas se componen de materiales muy distintos para satisfacer las exigencias del mercado respecto al diseño y la funcionalidad. Para evitar daños y reclamaciones hay que tener en cuenta ciertos aspectos tanto en el uso como en su limpieza.

Para obtener mejores resultados:

- Evite la acumulación de restos de jabón o sarro limpiando el producto Hansgrohe cuando sea necesario.
- Seleccione un agente de limpieza diseñado específicamente para el tipo de producto.
- **No** use estos tipos de limpiadores, ya que causarán daño a su producto Hansgrohe:
 - ✘ Agentes limpiadores que contengan ácido clorhídrico, fórmico, acético o lejía.
 - ✘ Polvos, paños o cepillos de limpieza abrasivos.
 - ✘ Limpiadores a vapor
 - ✘ Agentes de limpieza "sin enjuague".
- **Siempre** siga las instrucciones provistas por el fabricante del agente de limpieza.
- **No** mezcle los agentes de limpieza, a menos que esté indicado por el fabricante.
- **No** rocíe limpiadores directamente sobre el producto, ya que podrían caer gotas sobre las aberturas y espacios y causar daños. Cuando use limpiadores en spray, rocíe el limpiador sobre un paño suave o esponja.
- **Siempre** enjuague su producto Hansgrohe con agua limpia y séquelo y lístrelolo con un paño suave después de la limpieza.

Importante

- Los residuos de productos de aseo como jabón líquido, champú, gel de ducha, tintes de pelo, perfumes, lociones de afeitado y esmalte de uñas pueden dañar también los materiales. Enjuague el producto con agua limpia después de cada uso.
- Los residuos de limpiadores para lavatorios, bañeras o azulejos pueden causar daño a los grifos y accesorios. Enjuague inmediatamente cualquier derrame que haya sobre el producto de Hansgrohe.
- Tampoco pueden generarse depósitos de productos de limpieza o químicos debajo de los productos, p. ej. En un armario de lavabo. De lo contrario, los vapores generados pueden dañar los productos.
- **Los daños que resulten de un cuidado inadecuado o uso de agentes de limpieza inadecuados no están cubiertos por la garantía.**
- **Si se daña un componente del producto, reemplácelo, ya que existe riesgo de lesión.**

Limited Consumer Warranty

This product has been manufactured and tested to the highest quality standards by Hansgrohe, Inc. (“Hansgrohe”). This warranty is limited to Hansgrohe products that are purchased by a consumer in the United States or Canada after March 1, 1996, and installed in either in the United States or in Canada.

WHO IS COVERED BY THE WARRANTY

This warranty extends to the original purchaser only. This warranty is non-transferable.

WHAT IS COVERED BY THE WARRANTY

The warranty covers only your Hansgrohe manufactured product. Hansgrohe warrants this product against defects in material or workmanship as follows:

Hansgrohe will replace at no charge for parts only or, at its option, replace any product or part of the product that proves defective because of improper workmanship and/or material, under normal installation, use, service and maintenance. If Hansgrohe is unable to provide a replacement and repair is not practical or cannot be made in timely fashion, Hansgrohe may elect to refund the purchase price in exchange for the return of the product.

LENGTH OF WARRANTY

Replacement or repaired parts of products will be covered for the term of this warranty, as stated in the following two sentences. If you are a consumer who purchased the product for use primarily for personal, family or household purposes, this warranty extends for as long as you own the product and the home in which the product is originally installed. If you purchased the product for use primarily for any other purpose, including, without limitation, a commercial purpose, this warranty extends only (i) for 1 year, with respect to Hansgrohe & Commercial products, and (ii) for 5 years, with respect to Axor products.

THIS WARRANTY DOES NOT COVER, AND HANSGROHE WILL NOT PAY FOR:

- A. Conditions, malfunctions or damage not resulting from defects in material or workmanship.
- B. Conditions, malfunctions or damage resulting from (1) normal wear and tear, improper installation, improper maintenance, misuse, abuse, negligence, accident or alteration; (2) the use of abrasive or caustic cleaning agents or “no-rinse” cleaning products, or the use of the product in any manner contrary to the product instructions; or (3) conditions in the home such as excessive water pressure or corrosion.
- C. Labor and other expenses for disconnection, deinstallation, or return of the product for warranty service (including but not limited to proper packaging and shipping costs), or for installation or reinstallation of the product.
- D. Accessories, connected materials and products, or related products not manufactured by Hansgrohe.
- E. Any Hansgrohe or Axor product sold for display purposes.
- F. Rubbed Bronze finish is subject to a 3-year limited warranty. Chrome and all PVD finishes are covered by the limited lifetime warranty.
- G. Hansgrohe Water Filtration System is subject to a 1-year limited warranty. Warranty does not include replacement filters.

TO OBTAIN WARRANTY PARTS OR INFORMATION

Contact your Hansgrohe retailer, or contact Technical Service at:

Hansgrohe, Inc.
1492 Bluegrass Lakes Parkway
Alpharetta, GA 30004
Toll-free 800-334-0455

In requesting warranty service, you will need to provide:

1. The sales receipt or other evidence of the date and place of purchase.
2. A description of the problem.
3. Delivery of the product or the defective part, postage prepaid and carefully packed and insured, to:

Hansgrohe, Inc.
1492 Bluegrass Lakes Parkway
Alpharetta, GA 30004
Toll-free 800-334-0455

When warranty service is completed, any repaired or replacement product or part will be returned to you postage prepaid.

EXCLUSIONS AND LIMITATIONS

REPAIR OR REPLACEMENT (OR, IN LIMITED CIRCUMSTANCES, REFUND OF THE PURCHASE PRICE) AS PROVIDED UNDER THIS WARRANTY IS THE EXCLUSIVE REMEDY OF THE PURCHASER. HANSGROHE NEITHER ASSUMES NOR AUTHORIZES ANY PERSON TO CREATE FOR IT ANY OTHER OBLIGATION OR LIABILITY IN CONNECTION WITH THIS PRODUCT. HANSGROHE SHALL NOT BE LIABLE TO PURCHASER OR ANY OTHER PERSON FOR ANY INCIDENTAL, SPECIAL OR CONSEQUENTIAL DAMAGES, ARISING OUT OF BREACH OF THIS WARRANTY OR ANY IMPLIED WARRANTY (INCLUDING BUT NOT LIMITED TO ANY IMPLIED WARRANTY OF MERCHANTABILITY).

Some States do not allow the exclusion or limitation of incidental or consequential damages, so the above limitation or exclusion may not apply to you. This warranty gives you specific legal rights, and you may also have other rights that vary from state to state.

TO THE EXTENT PERMITTED BY LAW, ANY IMPLIED WARRANTIES OF MERCHANTABILITY AND FITNESS FOR A PARTICULAR PURPOSE, ARE LIMITED TO THE DURATION OF THE EXPRESS WARRANTY.

Some states do not allow limitations on how long an implied warranty may last, so the above limitations may not apply to you. You may be required by law to give us a reasonable opportunity to correct or cure any failure to comply before you can bring any action in court against us under the Magnuson-Moss Warranty Act.

PRODUCT INSTRUCTIONS AND QUESTIONS

Upon purchase or prior to installation, please carefully inspect your Hansgrohe product for any damage or visible defect. Prior to installing, always carefully study the enclosed instructions on the proper installation and the care and maintenance of this product. If you have questions at any time about the use, installation or performance of your Hansgrohe product, or this warranty, please write us or call us toll-free at 800-334-0455.

hansgrohe

Hansgrohe, Inc. • 1490 Bluegrass Lakes Parkway • Alpharetta, GA 30004
Tel. 800-334-0455 • Fax 770-360-9887

www.hansgrohe-usa.com